

JL Jig Series



Ajig1



Bjig1



Cjig2



CTjig2

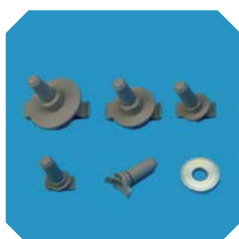

DLjig3



Ejig3



Gjig4



Magsy4



S-1jig5



S-3jig5



SKjig6

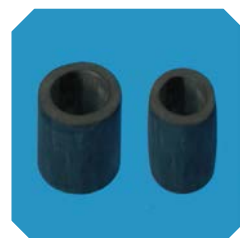

JLrubber corn6

A Jig

Product features, application

- During the setting of a insert with a mold, when a bolt cannot directly connect, this is the one to use.
- This can provide gap from the surface of insert thread to the concrete surface.

Cap(made by resin)

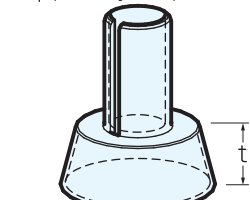

Main part(iron)

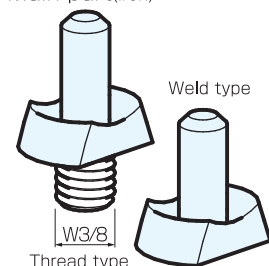

(Unit:mm)

| Main part | | | Cap | | | | |
|----------------|-------------|-----------|--------|----|------|-------|------------|
| Applied thread | Thread type | Weld type | Thread | t | Slit | Color | Invent-ory |
| M8 | ○ | ○ | M8 | 8 | ○ | White | ○ |
| M10 | ○ | ○ | M10 | 8 | ○ | White | ○ |
| M12 | ○ | ○ | M12 | 10 | ○ | White | ○ |
| M16 | ○ | ○ | M16 | 10 | ○ | White | ○ |
| M20 | ○ | ○ | M20 | 10 | ○ | White | ○ |
| M22 | ○ | ○ | M22 | 10 | ○ | White | ○ |
| M24 | ○ | ○ | M24 | 10 | - | White | ○ |
| W3/8 | ○ | ○ | W3/8 | 8 | ○ | Blue | ○ |
| W1/2 | ○ | ○ | W1/2 | 10 | ○ | Blue | ○ |
| W5/8 | ○ | ○ | W5/8 | 10 | ○ | Blue | ※ |

○Standard inventory

B Jig

Product features, application

- When using general bolt to do the setting, normally need to make a hole of the size more than bolt but by using B jig, we only need to make a hole with small size that can minimize the damage on the mold.
- This is the one to pull in the thread of insert from concrete surface.

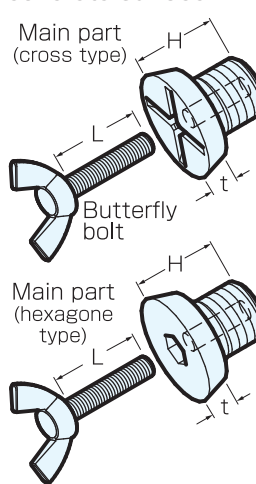

(Unit:mm)

| Bjig | H | t | Hex rench (opposite side) | inventory | | Butterfly bolt (M×L) |
|------|----|---|---------------------------|-----------|-----|----------------------|
| | | | | cross | hex | |
| M10 | 15 | 5 | 5 | ○ | ○ | M4×25 |
| M12 | 17 | 5 | 5 | ○ | ○ | M4×25 |
| M16 | 21 | 5 | 8 | ○ | ○ | M4×25 |
| M20 | 27 | 7 | 10 | ○ | ○ | M6×25 |
| M22 | 27 | 7 | 10 | ○ | ○ | M6×25 |
| M24 | 27 | 7 | 12 | ○ | ○ | M6×25 |
| M27 | 34 | 7 | 12 | ※ | ※ | M8×25 |
| W3/8 | 15 | 5 | 5 | ○ | ○ | M4×25 |
| W1/2 | 17 | 5 | 5 | ※ | ○ | M4×25 |
| W5/8 | 21 | 5 | 8 | ※ | ※ | M4×25 |

◎Standard inventory ※Production per order
Please consider the thickness of material for the L length.

How to do setting, How to Use

①Setting the main parts

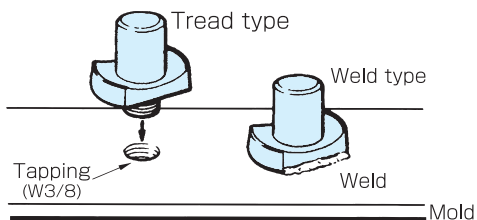

②Cap



③Insert ① to ②

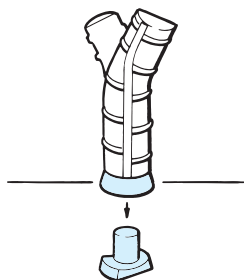

(Placing concrete after the setting)

④Demolding, remove a cap

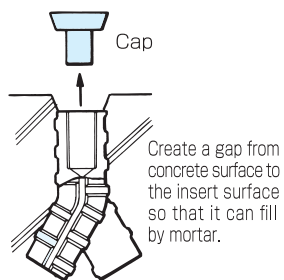

How to do setting, How to Use

① Set main parts into a Insert



②Attach the ①with composite panel by butterfly bolt.

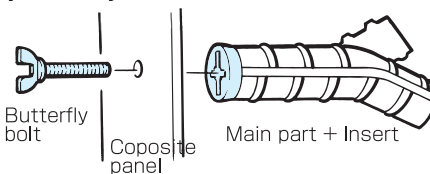

③Placing concrete
④Demolding (remove butterfly bolt)

⑤Remove jig

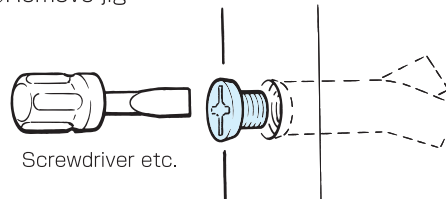

Create a gap from concrete surface to the insert surface so that it can fill by mortar.

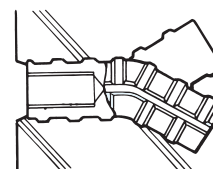

CJig

Product features, application

- When using general bolt to do the setting, normally need to make a hole of the size more than bolt but by using C jig, we only need to make a hole with small size.
- The surface of insert thread will be same with concrete surface.

| C jig | H | Hex rench (opposite side) | inventory cross | hex | Butterfly bolt (M×L) |
|-------|----|---------------------------------|--------------------|-----|----------------------------|
| M10 | 10 | 5 | ○ | ○ | M4×25 |
| M12 | 12 | 5 | ○ | ○ | M4×25 |
| M16 | 15 | 8 | ○ | ○ | M6×25 |
| M20 | 15 | 8 | ○ | ○ | M6×25 |
| M22 | 20 | 10 | ※ | ○ | M8×25 |
| M24 | 22 | 10 | ○ | ○ | M8×25 |
| M27 | 25 | 12 | ※ | ○ | M8×30 |
| W5/16 | 10 | 5 | ※ | - | M4×25 |
| W3/8 | 10 | 5 | ○ | ○ | M4×25 |
| W1/2 | 12 | 5 | ※ | ※ | M4×25 |
| W5/8 | 15 | 8 | ※ | ※ | M6×25 |
| W3/4 | 15 | 8 | ※ | ※ | M6×25 |

◎ Standard inventory ※ Production per order
 · Please consider the thickness of material for the L length.

CTJig PAT.

Product features, application

- This is to use as the attachment of fine ceramic insert.

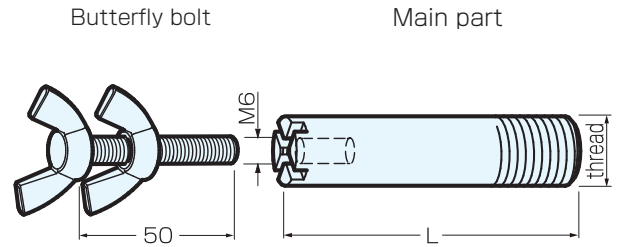

| FCI insert | Main part | | | Butterfly bolt(w/Butterfly nut) | | |
|------------|-----------|----|------|---------------------------------|----|------|
| | Thread | L | Iron | Thread | L | Iron |
| M12N×60 | M12 | 55 | ○ | M6 | 50 | ◎ |
| M12N×C84 | | 70 | ※ | | | |
| M16N×65 | M16 | 50 | ◎ | M6 | 50 | ◎ |
| M16N×75 | | 65 | ※ | | | |
| M16N×85 | | 70 | ※ | | | |
| M16N×C111 | | 95 | ※ | | | |

◎ Standard inventory ※ Production per order

How to do setting

① Set main parts into a Insert

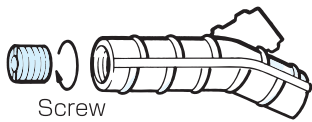

② Attach the ① with composite panel by butterfly bolt.

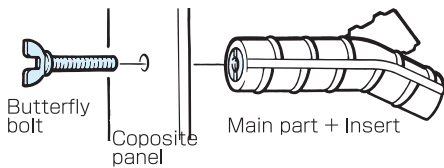

- ③ Placing concrete
- ④ Demolding (remove butterfly bolt)
- ⑤ Remove jig

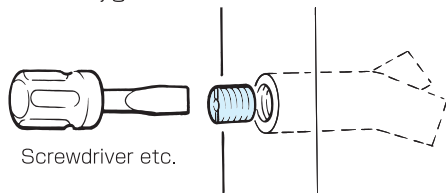

Surface of FCI will be the same level with the concrete surface.

How to do setting

① Set FCI with a main part.

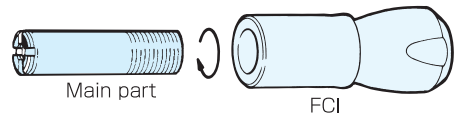

② Complete setting

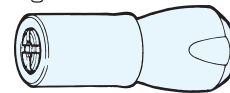

③ Attaching with composite panel.

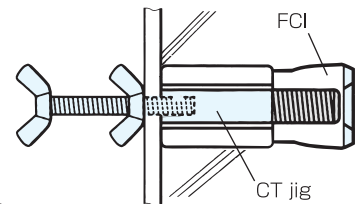

- ④ Placing concrete
- ⑤ Remove the butterfly bolt

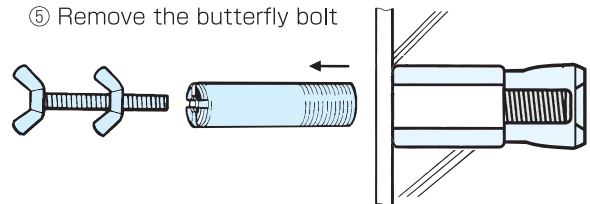

Surface of FCI will be the same level with the concrete surface.

CBMJig PAT.

Product features, application

- In general, we use tapping to set duct sleeve. But this way, we needed to do the tapping whenever the place of duct sleeve change which made composite panel many holes. It lead the durability of composite panel shorter. CBM jig can solve the issues and it also be able to avoid making holes on composite panel.
- It is able to use for Electrical box/Sleeve. (for construction).

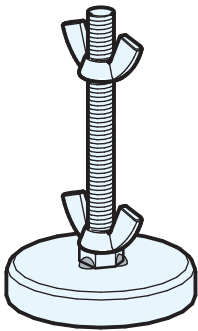

(Unit:mm)

| name | Magnet | head-cut bolt (1) Butterfly nut(2) Round washer(2) | Duct sleeve | Inventory |
|---------|---------|--|-------------|----------------------|
| 130 (L) | 77R | M12×630 | | Production per order |
| 130 (S) | | M12×480 | | |
| 75 | 66R NTT | M12×390 | | Production per order |
| 50 | 44R NTT | M6×350 | | |
| 25 | 25R NTT | M6×290 | | |

How to do setting, How to Use

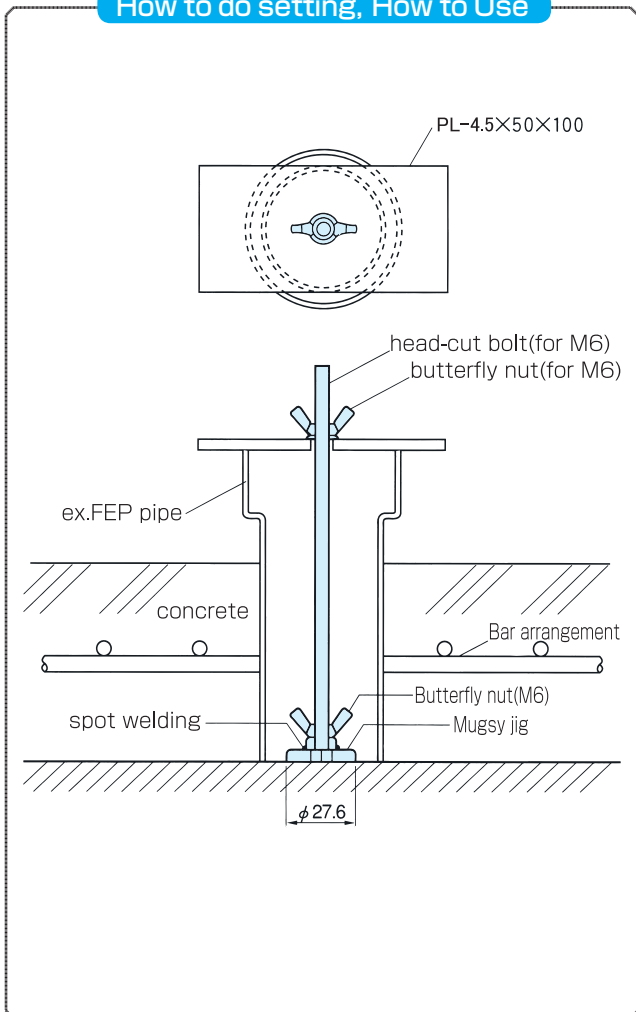

SKJig PAT.

Product features, application

- This is the one to enable a insert to be set to composite panel which can not directly fix by bolt.
- Enable to remain the surface of insert (screw part) by same level with concrete surface.
- Hole filling type can fill the holes that used to drilled on form panel.

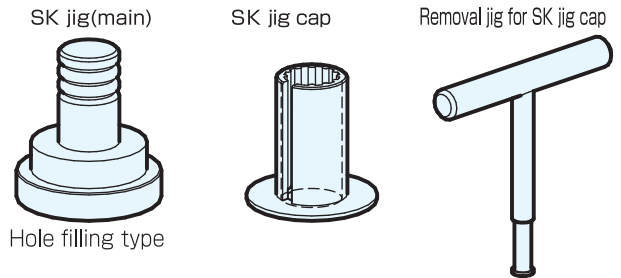

| thread | SK cap | Main part | | Removal jig |
|--------|--------|-----------|--------------|-------------|
| | | weld | hole filling | |
| M12 | ◎ | ※ | ※ | ※ |
| M16 | ◎ | ※ | ※ | ※ |

◎ Standard inventory. ※ Production per order

How to do setting, How to Use

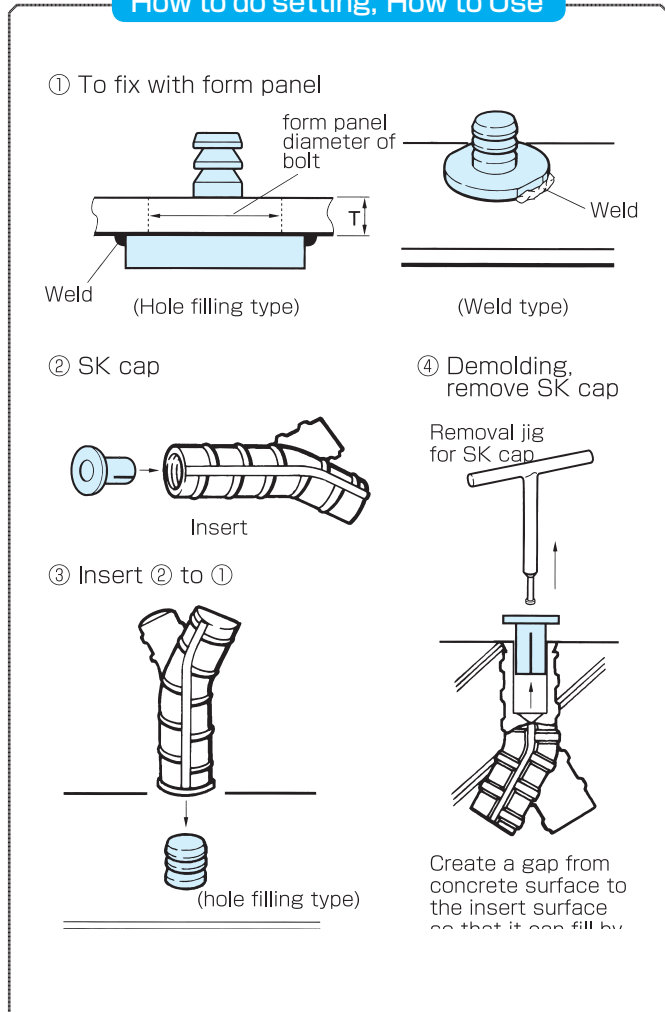

DLJig PAT.

Product features, application

- Is able to work only by one person instead of two, which enable to reduce the cost of workforce.
- Worker can handle the product easily that the work efficiency increase a lot.
- It is able to install to area that is difficult to use bolts.

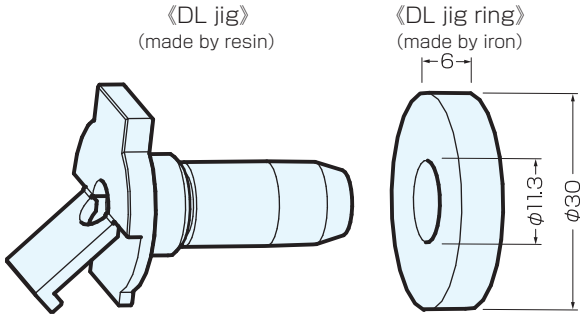

| Part code | Applicable former | DL jig | | DL jig ring | |
|-----------|-------------------|-----------|-----------|-------------|-----------|
| | | case pack | inventory | case pack | inventory |
| DL-1 | 1~1.3tons | 500 | ◎ | | |
| DL-2 | 2~2.5tons | 500 | ◎ | | |
| DL-4 | 4~5tons | 200 | ◎ | | ◎ |
| DL-8 | 8~12tons | 200 | ◎ | | |

◎ Standard inventory, * Production per order.

How to do setting, How to Use

- ① Insert DL jig to former
- ② Set Anchor after DL jig
- ③ After the setting, smash into a hole of form panel by hummer.
- ④ When demolding, you only need to pull the concrete product out so that the top part of the jig will cut easily.
- ⑤ Pull out the round part the left inside of former.

EJig PAT.

Product features, application

- This is the one to enable a insert to be set to composite panel which can not directly fix by bolt.
- It enable to avoid making big hole on a panel when putting insert.
- It enable to avoid making big hole on a panel when

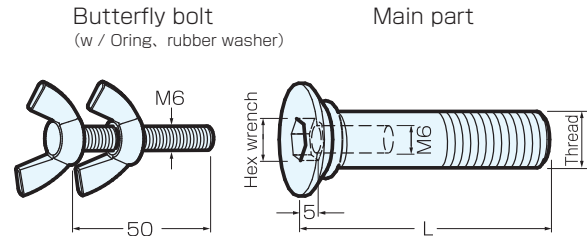

(Unit: mm)

| Main part | | | | Buttrefly bolt | |
|------------|-----|------------|-----------|----------------|-----------|
| FCI insert | L | Hex wrench | inventory | thread | inventory |
| M10N×43 | 45 | 6 | ※ | M6 | ◎ |
| M12N×60 | 55 | 8 | ◎ | M6 | ◎ |
| M12N×C-84 | 75 | 8 | ◎ | M6 | ◎ |
| M16N×65 | 55 | 10 | ※ | M6 | ◎ |
| M16N×85 | 75 | 10 | ※ | M6 | ◎ |
| M16N×C-111 | 100 | 10 | ◎ | M6 | ◎ |

◎ Standard inventory, ※ Production per order.

How to do setting, How to Use

- ① Set the main part with FCI
- ② Complete setting
- ③ Set on form panel
- ④ Placing concrete
- ⑤ Remove the butterfly bolt
- ⑥ Remove the form panel and E jig, insert a plug.

GJig PAT.

Product features, application

- This is to make concrete cover.
- Please use double sided tape when you would like to set inserts without making a hole on form panel.

《G jig》 (made by rubber)

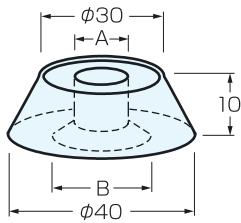

《Flush bolt》

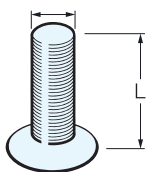

| Thread | Length(φ) | | inventory | Note |
|--------|-----------|----|-----------|--|
| | A | B | | |
| M12 | 13 | 26 | ◎ | Length of flush bolt will be decided upon the thread length of insert. |
| M16 | 17 | 32 | ◎ | |

· The product made by iron will be available upon order.

《Double sided tape》 (large no hole)

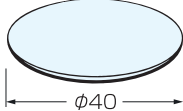

How to do setting, How to Use

① Setting G jig with a flush bolt.

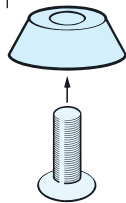

② Set G jig with a insert.

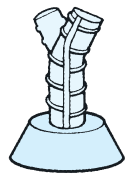

③ Set a double sided tape with G jig.

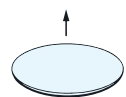

④ Set with form panel.

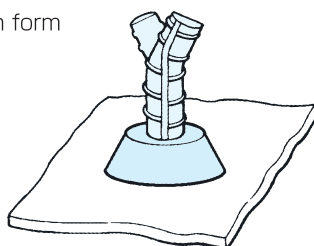

KHJig PAT.

Product features, application

- Enable the easy connection of hume pipe and pile with form panel.
- The product is match with especially to a form panel that have many mounting locations by shortening a mounting time and loss prevention of bolt and nut.
- The replacement of components is available.

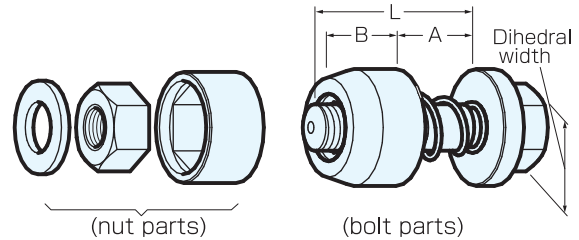

| Thread | specification | | | | inventory |
|--------|---------------|----|----------------|----|-----------|
| | A | B | Dihedral width | L | |
| W5/8 | 34 | 27 | 21(26) | 75 | ◎ |
| W5/8 | 34 | 27 | 21(26) | 85 | ◎ |
| W5/8 | 34 | 27 | 21(26) | 95 | ◎ |

◎ Standard inventory, () is production upon order.

How to do setting, How to Use

· Weld bolt part with form panel A, weld nut part with form panel B.

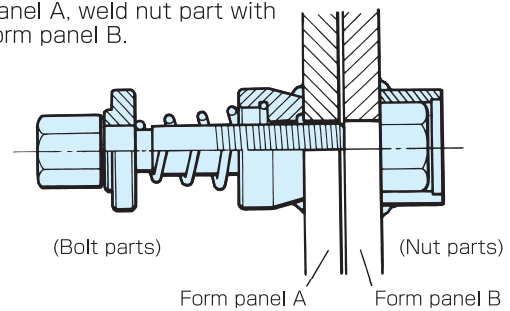

《Form panel of hume pipe》

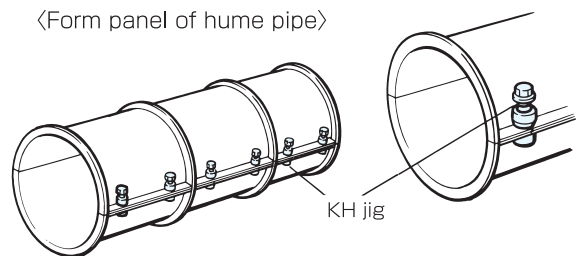

《Form panel of pile/pole》

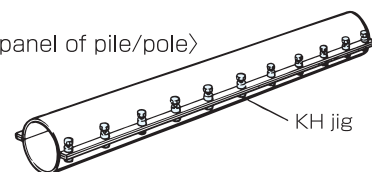

MJig PAT.

Product features, application

- The jig for insert by using powerful magnet.
- The jig enable to avoid making holes on form panel so that the toleration of form panel.
- Easy to set M jig to the concrete product.

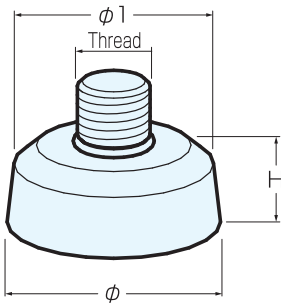

| Thread | φ | φ1 | H | (Unit: mm) | |
|--------|----|----|------|------------|----------------------|
| | | | | Inventory | Production per order |
| M12 | 32 | 29 | 18.5 | | |
| M16 | 47 | 43 | 17 | | |
| M20 | 60 | 54 | 20 | | |

Magasy PAT.

Product features, application

- Use magnet to attach inserts with form panel so that can avoid using bolts that let reduce the labor of drive screws which enable the drastically reduce the labor cost.
- This may be able to able to avoid the risk of worker to go into back and below of form panel .
- Deterioration of magnet is not so mush and the yoke is also solid and strong that enable to use for semipermanently.

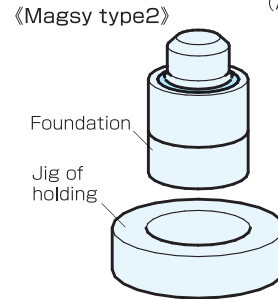
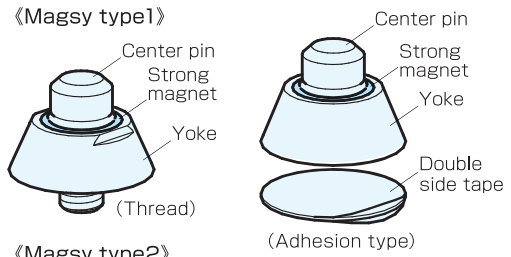

| Name | Thread | Inventory |
|-------|--------|----------------------|
| Type1 | M12 | Production per order |
| | M16 | |
| Type2 | M12 | Production per order |
| | M16 | |

* Deformed bar insert type and P insert type.

How to do setting, How to Use

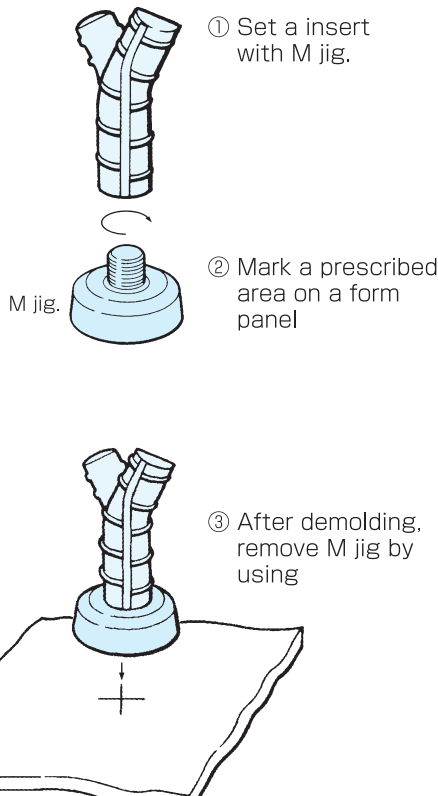

How to do setting, How to Use

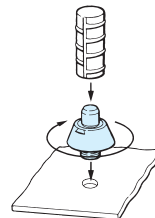

- <Magasy Type1 Thread type>
- 1) Tapping the W3/8 size on a form panel.
 - 2) Screwing Magasy into form panel.
 - 3) Stick insert to magnet part.
 - 4) Placing concrete.
 - 5) Remove concrete product and form panel.

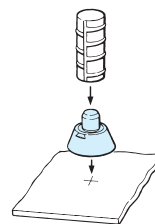

- <Magasy Type1 Tape type>
- 1) Mark on a form panel
 - 2) Put a double sided tape on a bottom of Magasy and stick with form panel.
 - 3) Stick a insert with magnet part.
 - 4) Placing concrete.
 - 5) Remove concrete product and form panel.

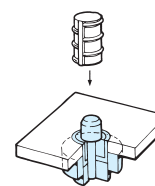

- <Magasy Type 2>
- 1) Press a hole at appointed place of form panel.
 - 2) Place a ring (magnet) at drilled hole of form panel and weld to form panel to fix.
 - 3) Place Magasy to a hole and arrange magnet part to form panel and fix with form panel by welding.
 - 4) Adsorp the magnet part with concrete.
 - 5) Placing a concrete.
 - 6) Remove concrete products and form panel.

S-1 Jig

Product features, application

- Create thread in A jig cap so that fill the gap of diameter of threaded hole of inserts that enables to use with all of inserts.
- Application:

《S-1 jig Cap》 (Made by resin)

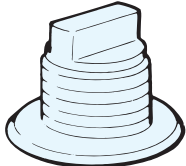

《S-1 jig main part》 (Made by Iron)

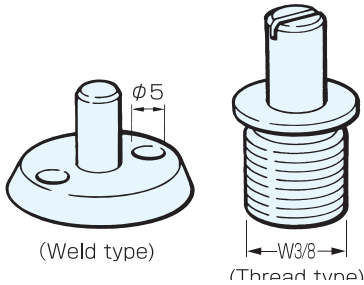

(Unit: mm)

| Thread | S-1 jig Cap | Main part(iron) | | |
|--------|-------------|-----------------|-------------|-----------|
| | | Name | Thread type | Weld type |
| M10 | ○ | 6φ | ○ | ○ |
| M12 | ○ | 6φ | ○ | ○ |
| M16 | ○ | 10φ | ○ | ○ |
| M20 | ○ | 14φ | ○ | ※ |
| M22 | ○ | 15φ | ○ | ○ |
| M24 | ○ | 17φ | ○ | ○ |
| W3/8 | ○ | 6φ | ○ | ○ |
| W1/2 | ○ | 6φ | ○ | ○ |
| W5/8 | ※ | 10φ | ○ | ○ |

○: Standard inventory.
 ※: Production per order.

S-2 Jig

Product features, application

- Add a rib at center of the jig with small slit in order to apply at side of form panel.
- It is no need to remove the jig from form panel when demolding, the shear created by demolding would break a slitted part of the jig.
- It would be possible to attaching inserts only at oneside of form panel, that enable a one person work.
- Application: Attachment of insert to the place out of reach that unable to either set or remove insert by bolt on form panel.

《S-2 Jig》

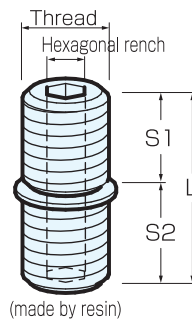

(Unit: mm)

| Thread | S1 | S2 | L | Hexagonal Reech | Inventory |
|--------|----|----|----|-----------------|-----------|
| M10 | 10 | 10 | 20 | 5 | ○ |
| M12 | 15 | 13 | 28 | 5 | ○ |
| M16 | 21 | 14 | 35 | 6 | ○ |

How to do setting, How to Use

Hint When setting jig cap and insert, if you paint oil/grease would help the easy removal of jig cap and limewash flow prevention.

- ① Do tapping on form panel with W3/8, and then set S-1 jig into a tapped hole.
 - Diagram: Shows a screw being used to tap a hole in a form panel. Labels include 'Screw by driver', 'Tapping(W3/8)', 'form panel', 'Jig', and 'Weld'.
- ② Screw jig cap into Insert by using driver.
 - Diagram: Shows the S-1 jig cap being screwed onto the insert. Label: 'Screw'.
- ③ Set a insert with Jig cap into form panel, and placing concrete.
 - Diagram: Shows the insert with the jig cap being placed into the form panel. Label: 'Jig'.
- ④ Remove from form panel (Move to axial direction of insert)
 - Diagram: Shows the jig cap being removed from the insert. Label: 'Jig for removal'.
- ⑤ Screw and remove the jig cap remaining within insert by driver. (no need to remove if use the cap for protection)
 - Diagram: Shows the jig cap being removed from the insert. Label: 'Screw'.

How to do setting, How to Use

Hint When setting jig cap and insert, if you paint oil/grease would help the easy removal of jig cap and limewash flow prevention.

- ① Tapping with a size of thread on form panel.
 - Diagram: Shows a hole being tapped into a form panel. Label: 'form panel'.
- ② Drill S2 jig (opposite side of hex reech) into insert.
 - Diagram: Shows the S2 jig being drilled into the insert. Label: 'Drill in'.
- ③ Insert with S2 jig into hole for thread on a form panel, and then placing concrete.
 - Diagram: Shows the S2 jig being inserted into the form panel. Label: 'form panel'.
- ④ Demold a product. When demolding, the S2 jig will divided.
 - Diagram: Shows the S2 jig being removed from the insert. Label: 'form panel'.
- ⑤ Remove S2 jig that remain at insert and form panel by hexagonal reech etc. (as for jig remain in insert can be remained for protection)
 - Diagram: Shows the S2 jig being removed from the insert. Label: 'Remove'.
- ⑥ Insert setting completed
 - Diagram: Shows the final setup with the S2 jig in place. Label: 'Drill in'.

S-3 Jig

Product features, application

- Create a tiny rib at middle of thread part and headed part of jig in order to use at side of form panel.
- It is no need to remove the jig from form panel when demolding, the shear created by demolding would break a slitted part of the jig.
- It would be possible to attaching inserts only at surface side of form panel, that enable a one person work.
- Application: Attachment of insert to the place out of reach that unable to either set or remove insert by bolt on form panel.

《S-3 Cap》 《Jig for removal》

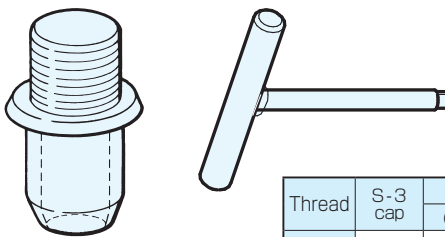

《S-3 Ring》

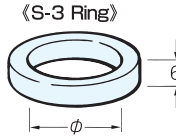

| Thread | S-3 cap | S-3 ring | | jig for removal |
|--------|---------|----------|-----------|-----------------|
| | | (φ) | inventory | |
| M10 | ○ | 11φ | ○ | ○ |
| M12 | ○ | 11φ | ○ | ○ |
| M16 | ○ | 17φ | ○ | ○ |
| M20 | ○ | 17φ | ○ | ○ |
| W3/8 | ○ | 11φ | ○ | ○ |
| W1/2 | ※ | 11φ | ○ | ○ |
| W5/8 | ※ | 17φ | ○ | ○ |

○ : Standard inventory

How to do setting, How to Use

Hint When setting jig cap and insert, if you paint oil/grease would help the easy removal of jig cap and limewash flow prevention.

- ① Weld S ring or PL12-16 sized (50x50) steel plate on back of form panel.
- ④ Demolding a product (When demolding, the shear created divide slitted part of the jig located at surface of form panel.)

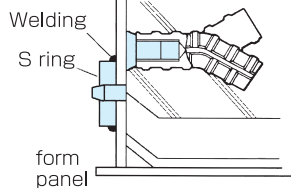
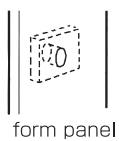

- ② Drill the jig into insert by screw driver.



- ⑤ Screw and remove the jig cap remaining within insert by driver. (no need to remove if use the cap for protection)

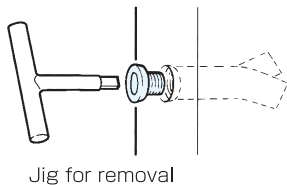

- ③ Set a insert with the Jig into form panel by using hummer, and then placing concrete.

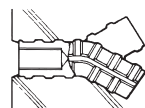
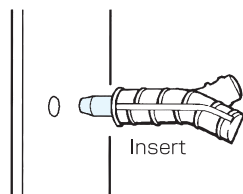

Pakit Jig PAT.

Product features, application

- Add a rib at center of the jig with small slit in order to apply at side of form panel.
- It is no need to remove the jig from form panel when demolding, the shear created by demolding would break a slitted part of the jig.
- It would be possible to attaching inserts only at oneside of form panel, that enable a one person work.
- Application: Attachment of insert to the place out of reach that unable to either set or remove insert by bolt on form panel.

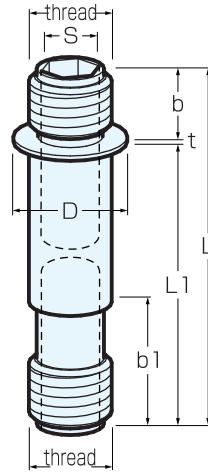

| Thread | Pakit Jig | | | | | | | Hex rench(S) |
|----------------|-----------|------|----|----|----|-----|-----------|--------------|
| | L | L1 | b | b1 | D | t | Inventory | |
| M12 (FCM12x60) | 65 | 51.5 | 13 | 20 | 17 | 0.5 | ○ | 6 |
| M16 (FCM16x65) | 73 | 58 | 14 | 25 | 22 | 1 | ○ | 10 |

○ : Standard inventory

How to do setting, How to Use

Hint When setting jig cap and insert, if you paint oil/grease would help the easy removal of jig cap and limewash flow prevention.

- ① Tapping with a size of thread on form panel.
- ④ Demolding a product. When demolding, the Pakit jig will be divided.

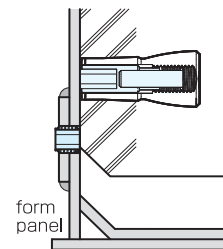
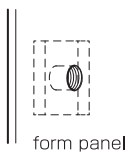

- ② Drill Pakit jig (opposite side of hex rench) into insert.



- ⑤ Remove Pakit jig that remain at insert and form panel by hexagonal rench etc. (as for jig remain in insert can be remained for protection)

- ③ Insert with Pakit jig into hole for thread on a form panel, and then placing concrete.

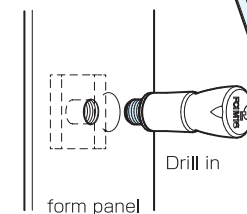
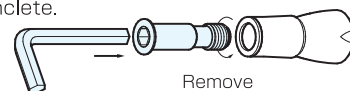

- ⑥ Insert setting completed

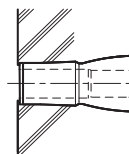

JL Rubber cone

Product features, application

- This is to be used as countermeasure for salt amage as of bridge and other constructions by securing certain level of a concrete cover, and easy to remove.
- When attaching with insert, the rubber deformed and tightly connected, and secure a certain level of a concrete cover. The rubber corn is made by a special rubber. It will not remove even after filling with mortar.
- When demolding, the rubber form go back to original and easy to remove. It can be used continuously so it is economical product.

For M12 (beer barrel type)

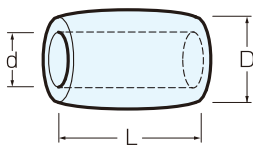

For M16~M24 (Straight type)

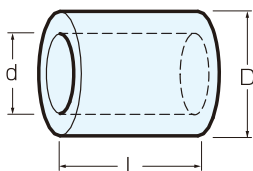

(Unit:mm)

| name (φ) | Outer diameter (inner) | thread size | L | inventory |
|----------|------------------------|-------------|----|-----------|
| 14 | 24 (14) | M12 W1/2 | 33 | ◎ |
| 18 | 28 (18) | M16 W5/8 | 33 | ◎ |
| 22 | 32 (23) | M20 M22 M24 | 33 | ◎ |

◎ : Standard inventory

How to do setting

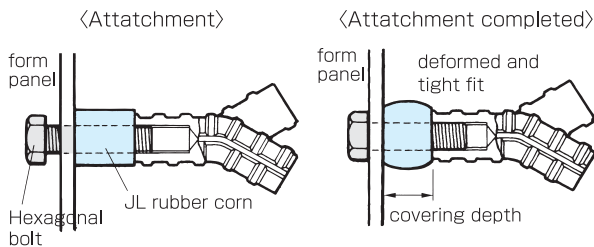

<Demolding and finishing>

After using scaffolding material, do fill by mortar.

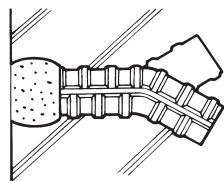

How to Use

<Example at bridge>

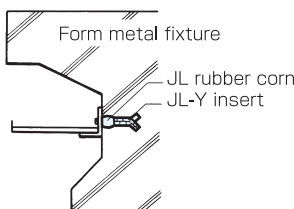

<Securing covering depth for inserts in precast concrete products>

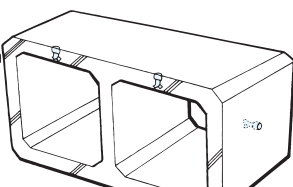

HJ Magnet Jig PAT.P

Product features, application

- Easy to setting and removal. No slipping by magnetic jig for insert that contribute labor saving. When demolding to vertical direction, only pull up the product. For demolding to horizontal direction, remove anti-slipping pin then pull up.
- Easy maintainance of form panel
Only need to put 5mm hole on form panel, and it is easy to repairing.
- Easy aftertreatment.
After demolding, remove HJ magnet jig from concrete product by using dedicated jig for the removal. We have dedicated cap to filling hole as optional.

For non-FCI For FCI Anti-slipping pin

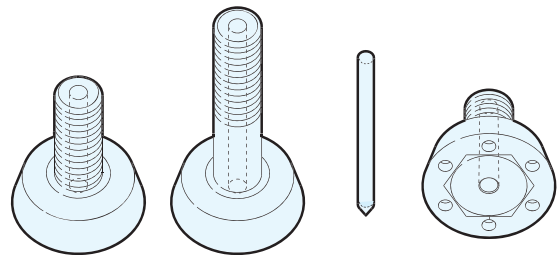

Standard design

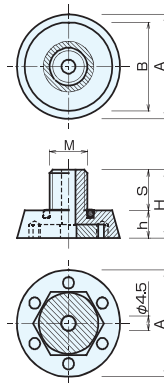

Standard size

(Unit:mm)

| | Thread (M) | Outer diameter (A/B) | Height | | Length (S) | Inventory |
|---------------|------------|----------------------|---------------------|----|------------|---------------------|
| | | | H | h | | |
| For FCI | M10 | 33/28 | 43 | 8 | 35 | Production on order |
| | M12 | 33/28 | 53 | 8 | 45 | |
| | | | 73 | 8 | 65 | |
| M16 | 33/28 | 58 | 8 | 50 | | |
| | | 78 | 8 | 70 | | |
| For Non-FCI | M10 | 33/28 | 20 | 8 | 12 | |
| | M12 | 33/28 | 20 | 8 | 12 | |
| | M16 | 33/28 | 23 | 8 | 15 | |
| | M20 | 47/42 | 27 | 12 | 15 | |
| | M22 | 47/42 | 32 | 12 | 20 | |
| | M24 | 47/42 | 34 | 12 | 22 | |
| Jig to remove | | | Each size is common | | | |

How to do setting

- ① Set anti-slipping pin on a magnet jig.
- ② Drill in a magnet jig into insert.

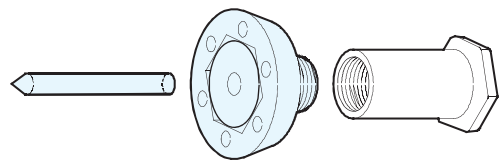

- ③ Setting jig and insert

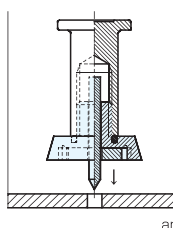

- ④ Set ③ with steel form panel by magnet

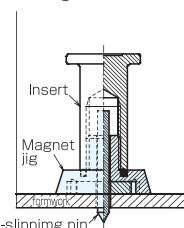

- ⑤ After concrete placement, demolding, and remove the jig.

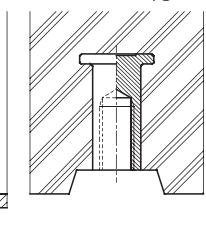



Japan Life Co., Ltd.
ジャパンライフ株式会社
<http://www.japanlife.co.jp>